



## Content

1	Overview of applications and system configurations .....	1
1.1	Solar thermal technology .....	1
1.2	General Heating (GH) .....	2
1.2.1	Heating of large buildings .....	3
1.2.2	District heating and Local district heating .....	3
1.3	General Cooling (GC) .....	4
1.3.1	General .....	4
1.3.2	State of the art .....	5
1.3.3	Cooling and dehumidification technologies .....	5
1.3.4	District cooling.....	8
1.4	Process Heating (PH) .....	10
1.5	Process Cooling (PC) .....	11
1.6	Water heating (WH).....	11
1.7	Swimming Pool Heating (SH) .....	11
1.8	Combination solar thermal plants with a heat pump Solar Combination with a heat pump (SCHP).....	11

# 1 Overview of applications and system configurations

## 1.1 Solar thermal technology

Solar thermal systems use free energy from the sun (solar radiation) to produce useful heat in a first instance. The solar radiation which is received on the earth plane is called "global radiation", which is made up of direct and diffuse radiation. Depending on the type of collector, in addition to the direct radiation it is also possible to use the diffuse radiation.

The generated heat can be used for different applications and combinations of applications. In the TASK 45 the following classification will be used:

- General Heating (GH)
- General Cooling (GC)
- Process Heating (PH)
- Process Cooling (PC)
- Water Heating (WH)
- Swimming Pool Heating (SH)
- Relevant Combination:
  - GH & GC

Typical clients are:

- district heating systems
- office buildings, conference centers, museums and airports
- apartment houses, hotels, hospitals, schools
- food and beverage industry, washing and galvanizing processes
- sport centers and swimming pools

Low operating and maintenance costs combined with a long plant life and escalating fossil fuel prices make solar thermal a very attractive investment on a life cycle cost basis when compared to a fossil fuel plant or electric powered systems. In addition solar thermal is environmentally friendly and provides significant CO<sub>2</sub> reductions.



Most people are familiar with solar water heaters found on homes. Large scale commercial solar thermal is much different due to the system engineering required and the selection and assembly of very cost effective and high quality components to insure proper operation and a long life demanded in a commercial operation.

Depending on different application and providers are on the market various collector types available:

- Flat plate standard – single glazing
- Flat plate high performance – double glazing or improved design
- Evacuated tube collector
- Fresnel collector
- Parabolic collector
- Integrated facade solar collector
- Swimming pool absorbers (un-glazed collectors)

Solar Process Heating, Cooling and General Cooling need in general higher operating temperatures than other applications. Collectors who provide such high temperatures are basically more expensive than collectors made for lower operating temperatures.

The heat transfer fluid (usually a glycol-water mixture - frost proof) in the primary circuit is pumped through the collectors, where it can absorb the heat of the sun. A heat exchanger delivers the heat to the secondary circuit, which supplies the consumer's heat system. In most systems, storage is integrated to bridge timing differences between heat production and heat consumption.

Solar systems in areas without sub-zero temperatures can use water as a heat transfer medium (no frost), and thus is no heat exchanger between primary circuit and storage necessary.

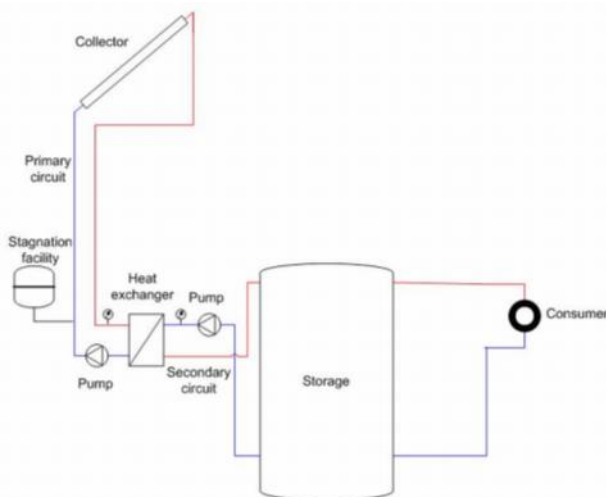

Fig. 1: Basic scheme of a solar thermal plant

## 1.2 General Heating (GH)

The main application General Heating includes the space heating of large buildings, district heating and local district heating, as well combinations of different applications.



### 1.2.1 Heating of large buildings

Solar systems for hot water preparation (domestic hot water - DHW) and Local Heating (LH) support in single- and multi-family houses are very well known. Here, the solar heat is stored locally in a storage tank and distributed over the central hot water system to the consumers in the house.

### 1.2.2 District heating and Local district heating

Solar district heating is the provision of hot water from solar energy and distributed through district heating networks (or in block or local heating systems by smaller installations).

Solar district heating systems can feed heat into sub stations in connected buildings or are directly connected to the district heating primary circuit on site.

District heating and solar heating has got increased interest all over Europe in recent years and more than 100 solar plants with more than 500 m<sup>2</sup> of solar collectors per plant have been put into operation since the mid 90's.

The majority of the large-scale plants supply heat to residential buildings in block and district heating systems. Typical operating temperatures range from low 30°C to high around 100°C (water storage).

Most of these plants have no storage as they can utilize the district heating network as storage (as long as they provide a small amount of heat in comparison to the total load in the district heating system). Without storage the system should cover not more than 90% of the summer load, to prevent stagnation of the plant due to lack of heat dissipation. By coverage of a high summer load and a time lag between heat production and heat dissipation the integration of heat storage is necessary. The combination with a storage for a local hot water supply of buildings or with a seasonal thermal storage for the store of solar energy collected in the summer time to the winter months are possible.

The type of feed-in scenarios can be basically divided as centralized and decentralized. The central supply is made locally at the heat source and is mostly used for local heating networks and multi-family houses.

With the integration of distributed solar thermal plants in existing district heating networks, there are several theoretical possibilities of heat supply:

#### 1) Extraction in the district heating return and feed in the district heating flow

Controlled heat input on the required flow temperature (flow matched). This type of feed in is preferred by the district heating operators (no change of return temperature, the higher part of the pumping costs contributes the solar thermal plant operator). Because of the higher feed in temperature are the collector yields about 10% lower than with the feed in scenario of extraction and feed in the return.

#### 2) Extraction and feed in the return

Due to the lowest possible temperatures has the plant the best efficiency. Often unfavorable for the district heating operators (higher heat losses, flow resistance, low efficiency of the primary heat source). The return temperature is often fixed by a contract with the main heat producers.

#### 3) Extraction and feed in the return

Here, the system operates under the highest required temperature with the lowest efficiency. The pump energy is covered by district heating grid pumps. This variant is due to the high temperatures already in the collector inlet for solar thermal plants rather not in use.

[1]

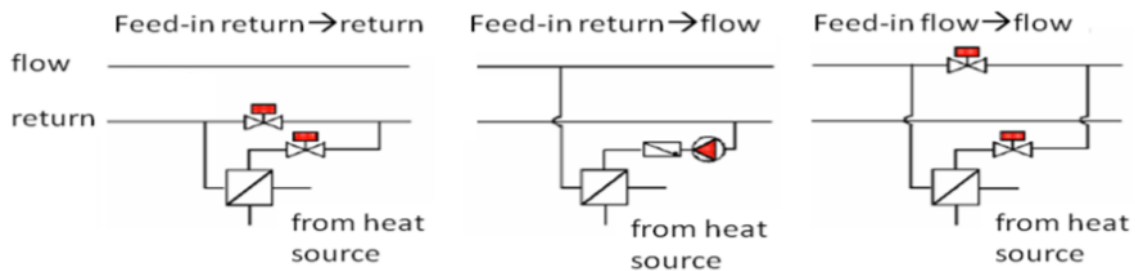

Fig. 2: Hydraulic integration of solar thermal feed-in (source: Wolfgang Streicher)

### 1.3 General Cooling (GC)

The main application General Cooling includes the cooling of large buildings, district cooling and local district cooling, as well combinations of different applications.

#### 1.3.1 General

Cooling and air conditioning is one of the largest consumers of energy in buildings. Due to the rising global electricity consumption, solar thermal driven cooling systems have received much attention in recent years.

Solar heat is used to run a heat driven cooling machine. The chiller provides cold water or air that is distributed in the building. The basics of this technology have been used for more than 100 years, but, until a short time ago, the temperatures needed for thermal chillers were too high for traditional solar panels such as those used on homes. A combination of improvements in chillers and the development of solar panels that allow production of higher temperatures have opened the market for solar thermal cooling.

Increasing demand on the electric grid is causing many problems (blackouts, brownouts, etc) and is partially due to increasing use of electric driven cooling on hot, sunny days. Solar cooling performs at its best on these hot, sunny days and can help to stabilize the electric supply by a significantly reduction of the electric demand.

Commercial buildings, office towers, resorts, health sector, educational buildings, large scale residential - all are excellent applications for solar air conditioning. Smaller scale units for private housing are under development and should soon be commercially available.

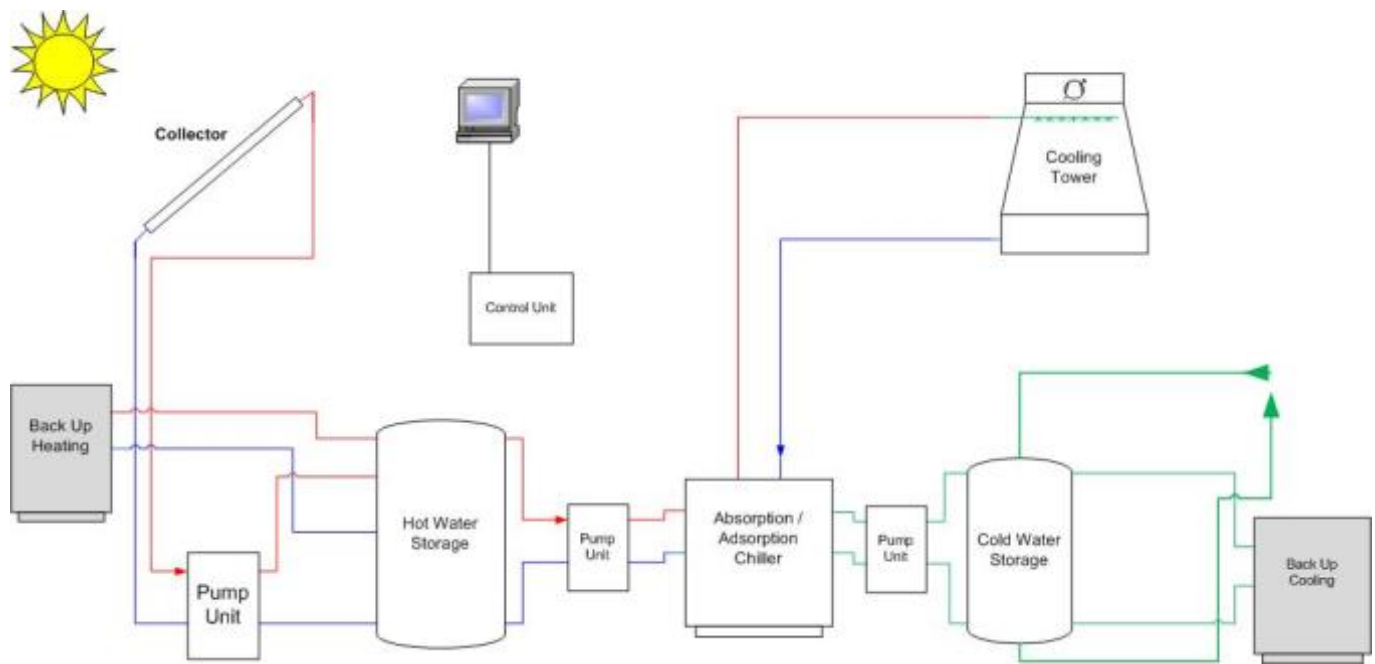

Fig. 3: Solar cooling schematic

### 1.3.2 State of the art

Heat-driven chillers/dehumidifiers can be divided into absorption chillers, adsorption chillers, desiccant cooling systems and other technologies.

To achieve a high capacity utilization of the solar cooling system, the system is mostly designed to cover the base cooling load. In most cases of room cooling systems, the cooling base load is 30 - 40% of the cooling peak load. This variant has also been found as the most economical way.

### 1.3.3 Cooling and dehumidification technologies

#### 1.3.3.1 Absorption chillers

The most solar assisted air conditioning systems which are in operation are equipped with absorption chillers (AbCH). AbCH consist of several heat exchangers designated as evaporator, absorber, generator and condenser. The refrigerant is mainly water or ammonia. The second needed working fluid (sorbent) is a LiBr-solution with water as refrigerant, or ammonia-water-solution if the refrigerant is ammonia.

#### Features of AbCH

- AbCH are designed for large solar applications (hundreds of kilowatts cooling capacity)
- Some AbCH are also available with lower capacities.
- Efficiency and capacities are small at low driving temperatures (<70°C)
- Providers are primarily from North America and Asia.

#### Cooling cycle



1. The generator is provided by heat. The refrigerant is driven off as vapour through the use of hot water or steam.
2. The refrigerant condenses in the condenser. The cooling water removes the heat of condensation.
3. Because of the evaporation of the refrigerant the temperature of the cold water is decreased.
4. The liquid sorbents absorbs the evaporative refrigerant meanwhile the absorption heat is removed by cooling water.

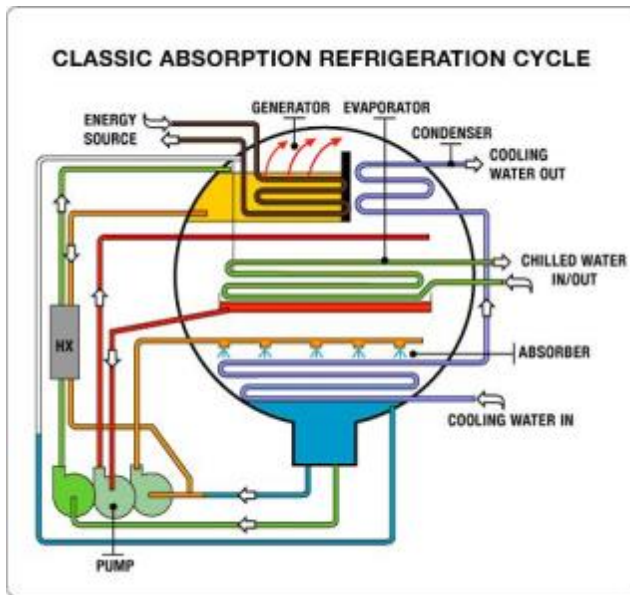

Fig. 4: Schematic of an absorption chiller [2]

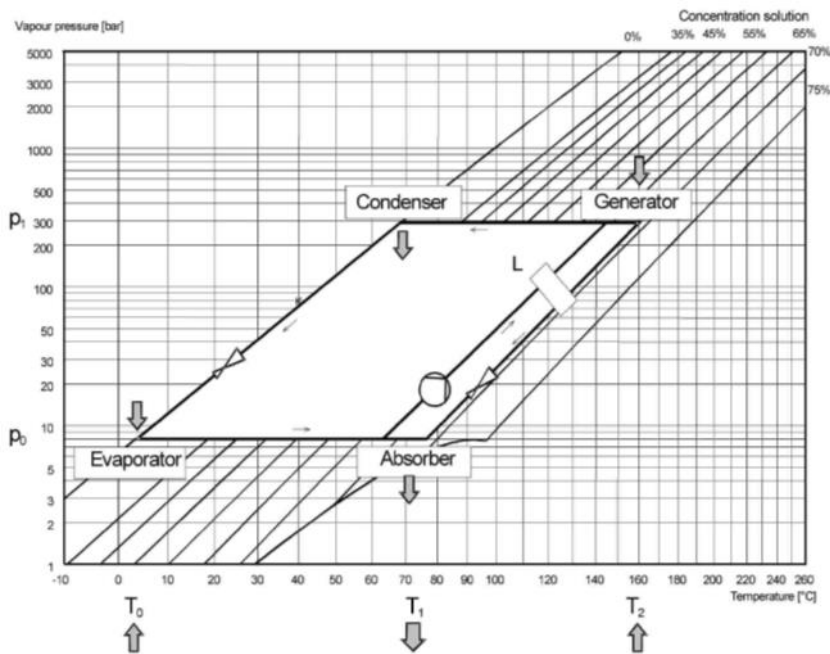

Fig. 5: Cooling cycle of an absorption process. Vapour pressure as a function of vapour temperature.

### 1.3.3.2 Adsorption chillers

Adsorption chillers (AdCH) work on a physical process in which the molecules of one substance are adsorbed on the internal surface of another substance. Due evaporation and adsorption of a



refrigerant (mainly water) is the production of useful cold possible. Regeneration of the sorption material is done by heat, e.g. from the solar thermal system.

### Features of AdCH

- Hot water temperatures of 60-80°C are suffices (use of standard flat plate collectors possible)
- AdCH are more expensive than absorption chillers
- Limited market choice
- Heavy weight and big volume of installations

### Cooling cycle

1. With the use of hot water is the refrigerant (adsorbed in the adsorbent) driven off.
2. The refrigerant condenses in the condenser. The heat of condensation is removed by the cooling water.
3. The condensate is sprayed in the evaporator which evaporates under low partial pressure. So is the production of useful cold possible.
4. The refrigerant vapour adsorbs in the absorber and the released adsorption heat is removed by cooling water.
5. If the adsorber is charged and the desorber regenerated, their functions are interchanged.

[Error! Bookmark not defined.]

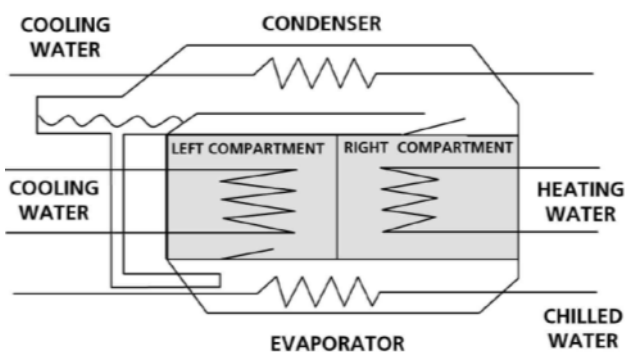

Fig. 6: Schematic of the internal chambers of an adsorption chiller [Error! Bookmark not defined.]

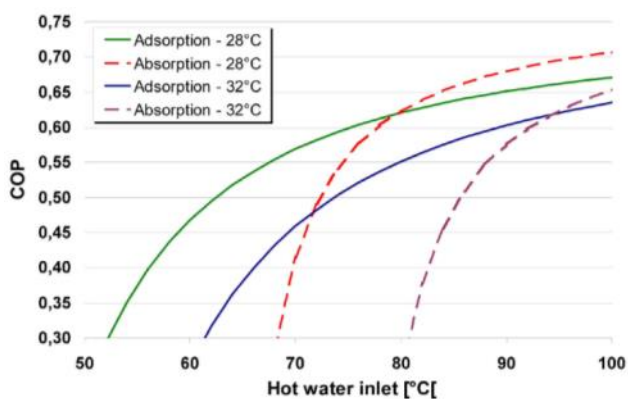

Fig. 7: COP of adsorption and absorption chiller as a function of heating water temperature (chilled water 9°C, cooling water 28 and 32 °C); [Error! Bookmark not defined.]



### 1.3.3.3 Desiccant Cooling System

In a desiccant cooling system removes desiccant (adsorbens) material moisture from the process air. Released heat increases the dry-bulb temperature during the dehumidification. In the first step is the dry-bulb temperature reduced by a heat recovery system and in the second step by an auxiliary cooling system. A coupling of desiccant cooling systems and solar thermal system is due to the relatively low needed temperature possible.

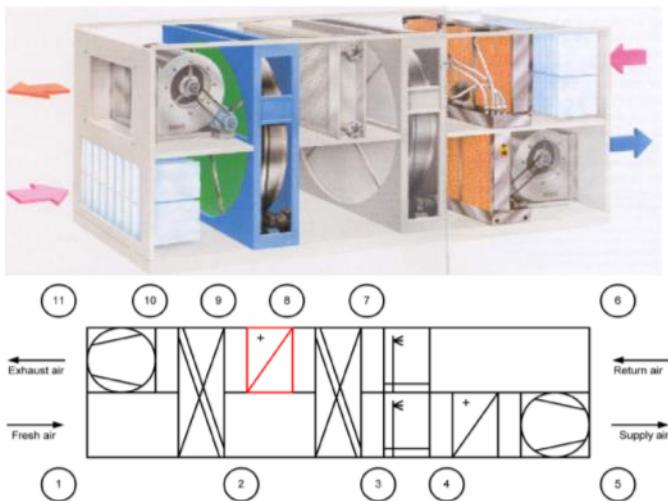

Fig. 8: Schematic of an Desiccant cooling system  
Cooling cycle

1. Fresh air is dehumidified from (1) to (2) by the desiccant wheel.
2. Reduction of the temperature (3) due the heat recovery system -> uses the lower temperature of the exhaust air (7).
3. Through evalporation of water, the humidifier realizes the temperature reduction, which increases (4).
4. Heat only in winter case necessary, the pressure increase in the fan increases the temperature (5).
5. Change of state in the room from (5) to (6).
6. Heat recovery from (7) to (8), in the supply air the exhaust air is humidified from (6) to (7)-> temperature is lowered.
7. The heater rises the exhaust air temperature from (8) to (9). The hot and relative dry air is used to regenerate the sorptive material, (9) to (10).

[Error! Bookmark not defined.]

### 1.3.4 District cooling

In a solar district cooling grid, the solar generated heat is central used for the production of cold and discharged through a pipe network to the buildings. For the production of the cold are absorption- and adsorption chillers useable. If the situation permits, cold water from lakes and the sea can be use for feeding the district cooling grid. Additional to the use of solar thermal a district cooling grid enables an efficient use of surplus heat of diverse sources (waste heat from power plants) to cool buildings.



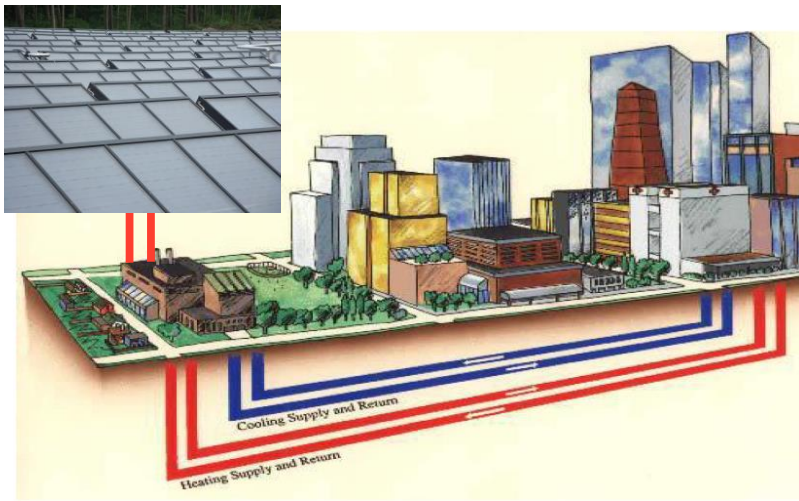

Fig. 9: Solar district cooling grid



## 1.4 Process Heating (PH)

In principle, the potential for solar thermal generation of process heat is enormous: In Europe, about 27% of the total final energy demand is heat consumed by the industry. Herein, about 30% of the total industrial heat demand occurs at temperature levels below 100°C. A significant part of this heat can be generated by solar thermal plants with common collectors. Temperatures over 100°C are reachable with high temperature- or concentrating collectors.

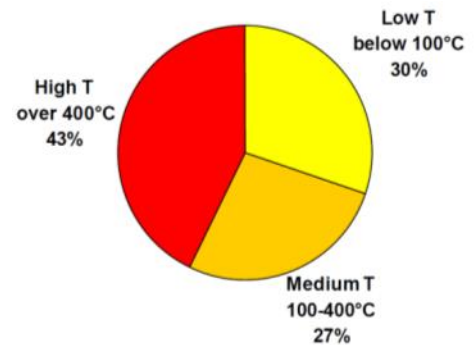

Fig. 10: Share of industrial heat demand by temperature level. Data for 2003, 32 countries: EU25 + Bulgaria, Romania, Turkey, Croatia, Iceland, Norway and Switzerland.[3]

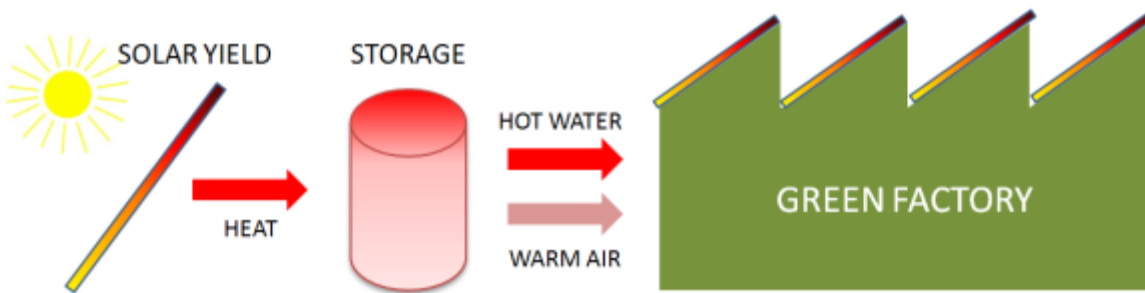

Fig. 11: Principle of solar process heating

Process heating plants are less complex with regards to solar cooling. They replace mostly oil and gas and can deliver up to 120°C. Especially food, beverage, wood or textile industries have a huge demand for heat. Another possibility is space heating for industrial buildings. Most systems are designed to provide large quantities of hot water or steam, depending on the used collector typ.

- Heating of hot water for washing or cleaning in food, textile industry, surface treatment
- Heating of make-up water for steam networks in bakeries, laundries
- Heating of baths or vessels for metallurgic processes
- Drying and conditioning of goods, tea, coffee, wood, fruits
- Distilling and chemical processes such as breweries, desalination, reverse osmosis
- Etc.



Fig. 13: Solar thermal process plant- hot water production used in the beverage industry (source: SOLID GmbH, Austria)



Fig. 12: Solar thermal process plant - steam production in chemical industry (source: Fichtner Solar GmbH, Germany)



## **1.5 Process Cooling (PC)**

Process cooling on basis of solar thermal energy works with the same principle explained in chapter 1.3. Compared to air conditioning for buildings the cooling loads for processes are usually more constant over the day. In order to achieve a higher solar fraction, the collector field and storage tank can be dimensioned larger to be able to provide a higher solar cooling fraction at the same level of risking stagnation conditions.

## **1.6 Water heating (WH)**

Solar systems for hot water preparation (domestic hot water) in single-family and multi-family houses are very well known. Here, the solar heat is stored locally in storage and distributed over the central hot water system to the consumers in the house.

## **1.7 Swimming Pool Heating (SH)**

Large pools must often be kept at a certain temperature level. For this purpose required energy can be covered to a certain extent by means of solar energy. Due to the low temperature level often swimming pool absorbers can be used, which consist entirely of plastic, mostly without a cover.

## **1.8 Combination solar thermal plants with a heat pump Solar Combination with a heat pump (SCHP)**

During the operation of solar thermal heat plants, the temperature level of the solar heat might not be high enough to be used in a process. Mostly in spring, autumn and also after sunset is the possibility given to use lower collector temperature due the integration of a heat pump system. Therefore heat pumps can be installed to reach the useful temperature levels more often and due to increase the solar fraction of the plant itself.

Heat pumps absorb heat at a low temperature levels, the working medium inside the heat pump evaporates at this low temperature level. The evaporated medium is shifted to higher pressure and temperature level by compression. On this higher temperature level, heat is transferred to a heat sink and the medium condensates. After the medium is relaxed in the valve, the cycle starts again with evaporation. The main heat pump types, adsorption or compression heat pumps have the same effect, but use different methods to reach higher temperature levels.

Heat pumps can be connected to the storage tank or in the primary solar circle. Heat source of the evaporator can be on the one hand the cold side of the storage tank, or on the other the primary solar circle. The heat sink for the condensator is mostly the warm side of the storage tank. Because of colder return temperatures and therefore less thermal losses the collector efficiency raises.

### Compression heat pump

Most of the heat pump systems work with the vapour compression cycle. The main components in this system are the compressor, the expansion valve and two heat exchangers referred to as evaporator and condenser. Those components build together a closed circuit. The working fluid or refrigerant circulates through the four components.



## Heating cycle

1. The temperature of the working fluid is kept lower in the evaporator than the temperature of the heat source. Thereby heat flows from the heat source to the working fluid, which evaporates.
2. Vapour from the evaporator is compressed to a higher pressure and temperature.
3. In the condenser enters the hot vapour, where it condenses and gives off useful heat.
4. At the end of the heating cycle the high pressure working fluid is expanded to the evaporator pressure and temperature in the expansion valve (original state). The working fluid enters again the evaporator.

[4]

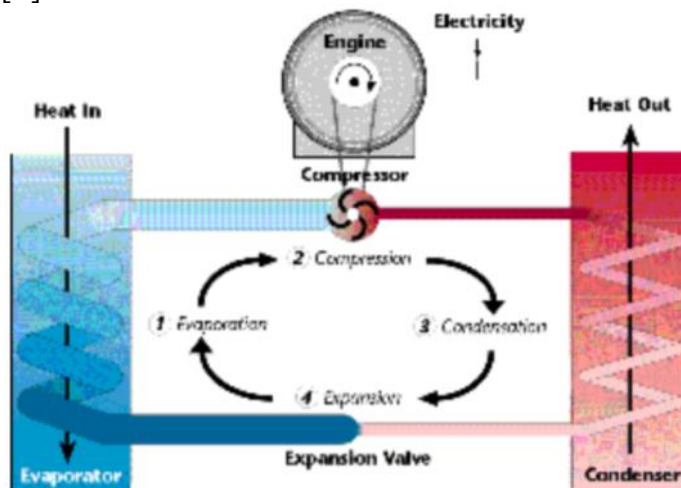

Fig. 15: Closed cycle, electric motor-driven vapour compression heat pump

The compressor is usually driven by an electric motor but is also possible by a combustion engine.

## Absorption heat pump

Absorption heat pumps are thermally driven. Beside solar thermal as heat source are also gas-fired, waste heat and high pressure steam are possible to drive the heat pump. Absorption systems use the liquids or salts, which are able to absorb the vapour of the working fluid.

Most common working pairs are:

- Water (working fluid) and lithium bromide (absorbent)
- Ammonia (working fluid) and water (absorbent)

The solution circuit of a thermal driven absorption system consists of an absorber, a solution pump, a generator and an expansion valve.

## Heating cycle

1. Low pressure vapour is absorbed in the absorbent. In this process heat is generated.
2. With the pump the solution are moved to the generator with a higher pressure, where the working is boiled off with an external heat supply at a high temperature.
3. The vapour (working fluid) condenses in the condenser while the absorbent is returned to the absorber over the expansion valve.
4. Useful heat at medium temperature can be used at the condenser and in the absorber. High temperature heat is supplied to the generator to run the process.

Compared to the compression heat pump a smaller amount of electricity is needed for the operation of the solution pump.

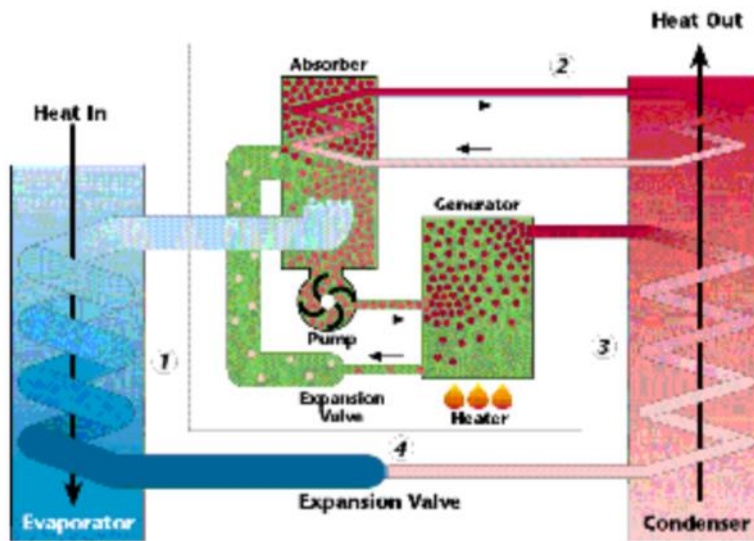

Fig. 16: Absorption heat pump

[4]

## 1.1 References:

- [1] Streicher, W.; Fink, C.; „8. Internationales Symposium für Sonnenenergienutzung“; 2006; Page 153-162.
- [2] “Vapour Absorption Cycle; awazpost; Internet site: <http://www.awazpost.com/tag/chilled-water/>; [12. Sept. 2011]
- [3] ECOHEATCOOL (IEE ALTENER Project), The European Heat Market, Work Package 1, Final Report published by Euroheat & Power
- [4] IEA Heat Pump Centre c/o SP Technical Research Institute of Sweden; “Heat pump technology”, Internet site: <http://www.heatpumpcentre.org/en/aboutheatpumps/heatpumptechnology/Sidor/default.aspx>, [13. Sept. 2011]